

Micro Power 600mA, High PSRR, Fast Transient Linear Regulator

General Description

The ASD2306 is a high performance linear regulator with tight load regulation and excellent transient response. It is designed to operate with wide input voltage range of 2.7 – 5.5. The device is capable of supplying 600mA of output current with a typical dropout Voltage of 650mV. The product is available in either fixed or adjustable output Voltage.

The linear regulator has been optimized for noise sensitive applications. Connecting a small capacitor from C_{BYP} to ground reduces output self noise and increase power supply ripple rejection. The device includes an enable pin for electrical on/off of the regulator. Forcing the enable pin to logic low shuts down the regulator.

The device offers complete short-circuit and thermal protection. The combination of these two internal protection circuits gives the device a comprehensive safety system to safe guard against extreme adverse operating conditions.

The ASD2306 is available in SOT23-5 and DFN3X3-8, and it is rated for -40°C to $+125^{\circ}\text{C}$ temperature range.

Features

- V_{IN} range: 2.7 – 5.5V
- Adjustable V_{OUT} as low as 1.27V
- 600mA maximum output current
- Low self noise
- 50 μA of typical supply current
- 600mV typical dropout voltage @ full load
- Enable (EN) pin for LDO on/off
- Optional Bypass for low high PSRR & output noise
- Stable with Electrolytic, Tantalum or Ceramic capacitors
- Short circuit protection
- Thermal shutdown protection
- -40°C to $+125^{\circ}\text{C}$ temperature range
- Available in SOT23-5 & DFN3X3-08 packages
- RoHS & WEEE compliant

Applications

- Wireless Communication Equipment
- Car Navigation System
- Set-Top Box
- PCMIC cards
- DVD drivers

Typical Application

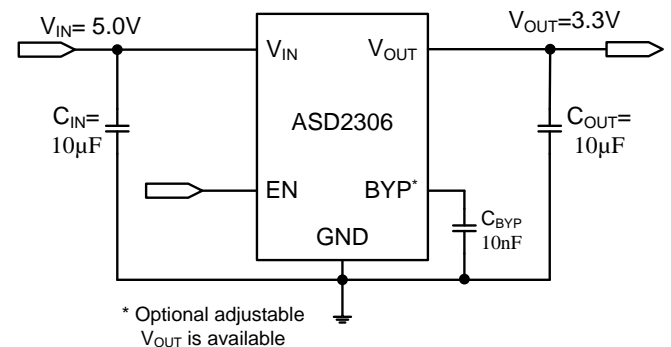

Pin Description

Symbol	Description
V_{IN}	Input supply pin. Connect a capacitor between this pin and ground.
GND	Ground connection.
EN	Enable pin. It controls the electrical on/off of the device. When connected to logic low, the device shuts off and consumes 1 μ A of current. A logic high will resume normal operation
Adj	Feedback Voltage. A resistor network of two resistors is used to set-up the output voltage connected between V_{out} and GND. The center tap of the two resistors is connected to Adj pin. This pin is available only for adjustable option.
BYP	Bypass pin. Connect an external capacitor from BYP to ground to bypass the noise generated by the internal bandgap. This improves power supply rejection ratio and output noise.
V_{OUT}	Regulated output Voltage. Connect a capacitor from this pin to ground.

Pin Configuration (Adjustable Option)

SOT23-5 (Top View)

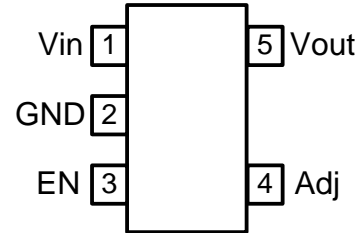

Pin Configuration (Bypass Option)

SOT23-5 (Top View)

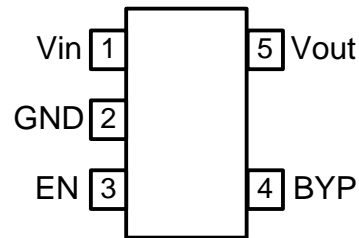

Pin Configuration

DFN3X3-8 (Top View)

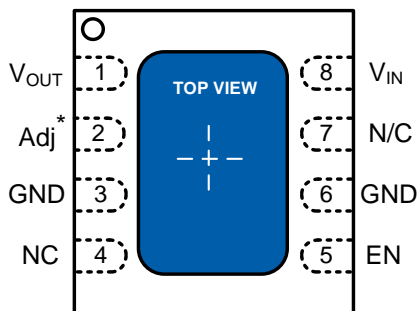

*available only for adjustable option

Absolute Maximum Ratings ⁽¹⁾

Maximum Input Supply Voltage	-0.3V to 7.0V
Enable Voltage	-0.3V to 7.0V
Feedback Voltage (FB)	GND-0.3V to $V_{IN}+0.3V$

Recommended Operating Conditions

Input Voltage	2.7 to 5.5V
Ambient Operating Temperature	-40°C to +125°C

Thermal Information ⁽²⁾

SOT23-5 θ_{JA}	300°C/W
Storage Temperature Range	-65 to 150°C
Lead Temperature (soldering 10s)	300°C
Junction Temperature	-40°C to +125°C

Electrical Characteristics

UNLESS OTHERWISE NOTED: $V_{IN}=5V$; $V_{OUT}=3.3V$; $C_{IN}=10\mu F$; $C_{OUT}=10\mu F$; $-40^{\circ}C \leq T_A = T_J \leq 85^{\circ}C$; $T_{J(MAX)} = 125^{\circ}C$; TYPICAL VALUES ARE $T_A = 25^{\circ}C$

Parameter	Symbol	Conditions	Min.	Typ.	Max.	Units
Output Voltage Range	V_O	Adjustable only	1.27		5.5	V
Maximum Output Current	I_O		600			mA
Load Regulation ³		$I_{OUT} = 1mA - 600mA$		0.5	1.5	%
Line Regulation ³		$V_{IN} = 2.7 - 5.5V$; $I_{OUT} = 10mA$	-0.3	0.05	0.3	%/V
Supply Current	I_Q	$V_{IN} = 2.7 - 5.5V$; $V_O = 1.8V$; No load		50	350	μA
Shutdown current	I_{SHD}	$V_{IN} = 5.5V$; $V_{EN} = GND$		25	50	μA
Current Limit	I_{LIM}			1.3		A
Dropout Voltage	V_{DO}	$V_{OUT} = 3.3V$; $I_{OUT} = 500mA$		0.60	0.750	V
		$V_{OUT} = 1.8V$; $I_{OUT} = 500mA$		1.0	1.2	
		$V_{OUT} = 1.2V$; $I_{OUT} = 500mA$		1.3	1.6	
Enable startup time	T_{SS}	$C_{BYP} = Open$; $C_{OUT} = 10\mu F$; $I_{OUT} = 0.1A$		600		μs
Feedback Voltage	V_{FB}			1.27		V
Enable Threshold Low	$V_{EN(L)}$				0.5	V
Enable Threshold High	$V_{EN(H)}$		1.5			V
Input Enable Low Current	$I_{EN(L)}$	$V_{EN} = 0V$		0.1	1.0	μA
Input Enable High Current	$I_{EN(H)}$	$V_{EN} = V_{in}$		0.3	1.0	μA
Ripple Rejection Ratio	PSRR	$F = 100Hz$, $I_O = 0.1A$; $C_{BYP} = open$		55		dB
Output Noise	e_n	$BW = 20 - 100KHz$; $I_O = 10mA$; $C_{BYP} = Open$		12		μV_{rms}
Thermal Shutdown	T_{SD}			155		$^{\circ}C$
Thermal Shutdown Hysteresis	T_{SD_HYS}			10		$^{\circ}C$

Notes:

1. Stresses above those listed in Absolute Maximum Ratings may cause permanent damage to the device.
2. Measured on approximately 1" square of 1oz copper
3. The ASD2306 is guaranteed to meet performance specifications over the -40°C to +125°C operating temperature range and is assured by design, characterization, and correlation with statistical process control.
4. Load regulation is measured using pulse techniques with duty cycle <5%.

Functional Block Diagram

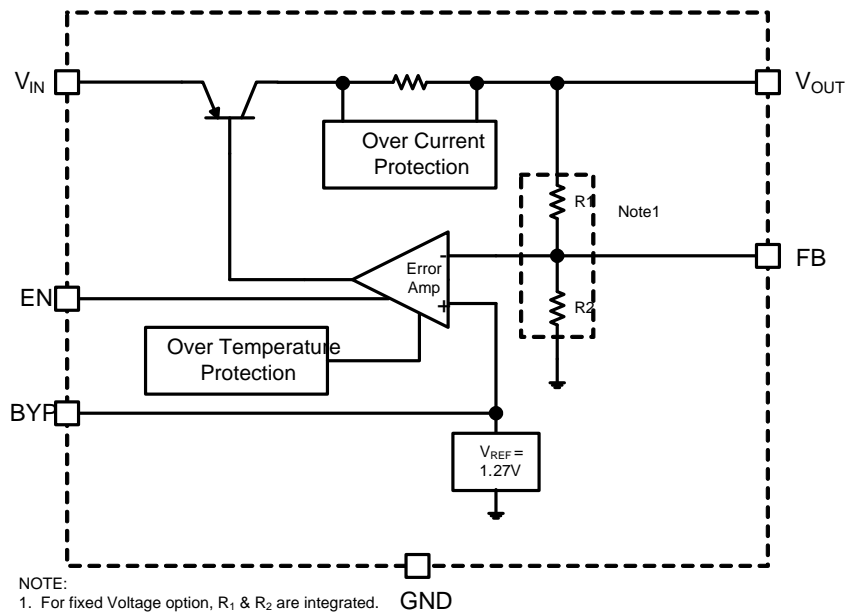

Typical Characteristics

Output Voltage vs. Input Voltage

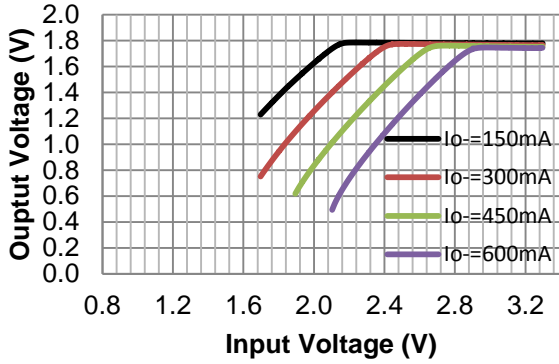

Output Voltage vs. Enable Voltage

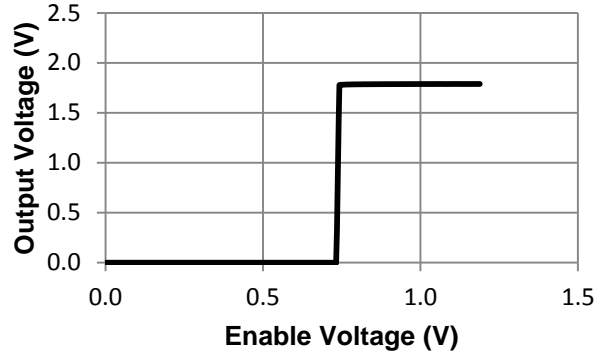

Line Regulation

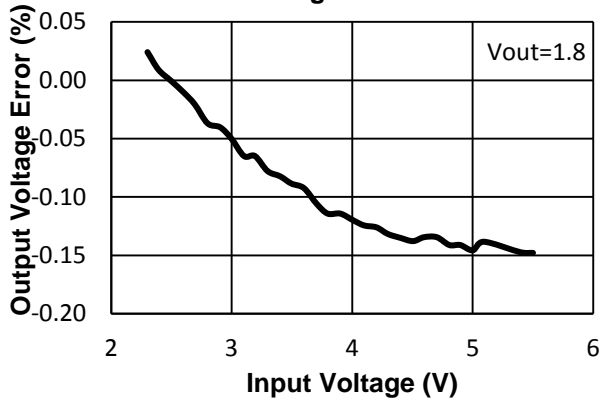

Load Regulation

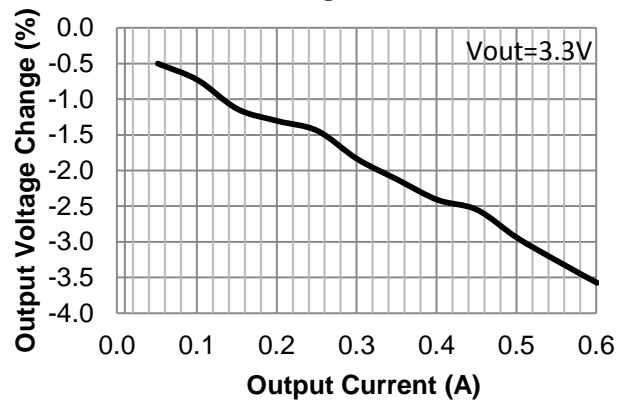

Supply Current vs. Load Current

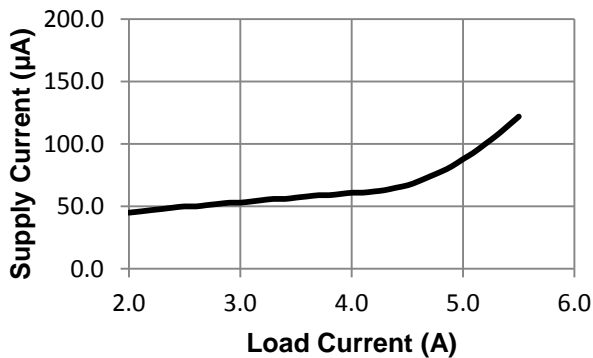

Shutdown Current vs. Input Voltage

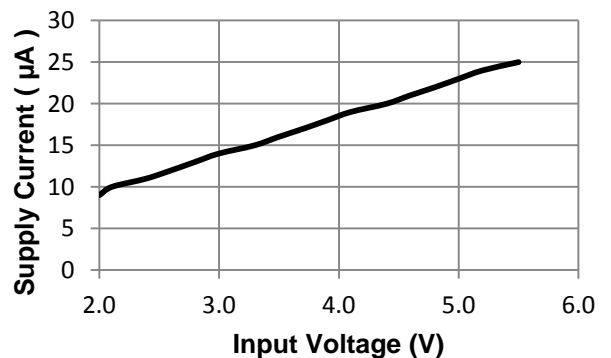

Typical Characteristics

Dropout Voltage vs. Output Current

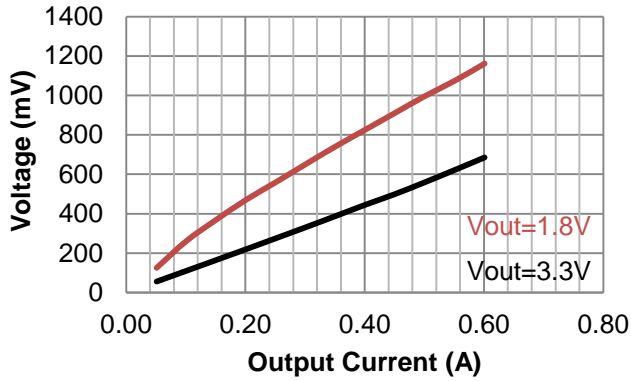

Enable Startup

$V_{IN}=V$; $V_{OUT}=V$; Load= A; $C_{IN}=10\mu F$; $C_{OUT}=22\mu F$

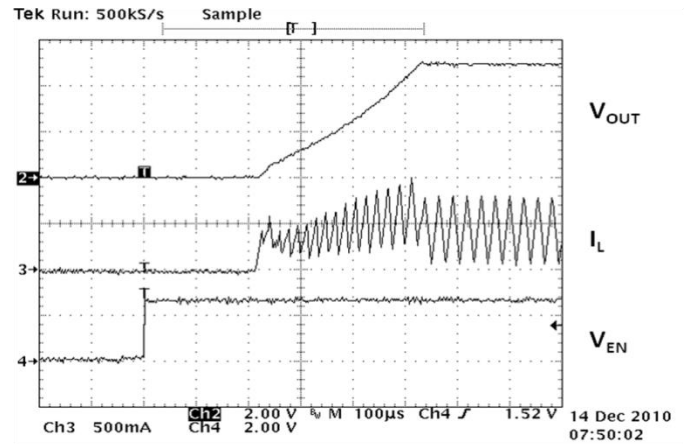

Transient Response

$V_{IN}=V$; $V_{OUT}=V$; Load Step= 0.27A; $C_{IN}=\mu F$; $C_{OUT}=\mu F$

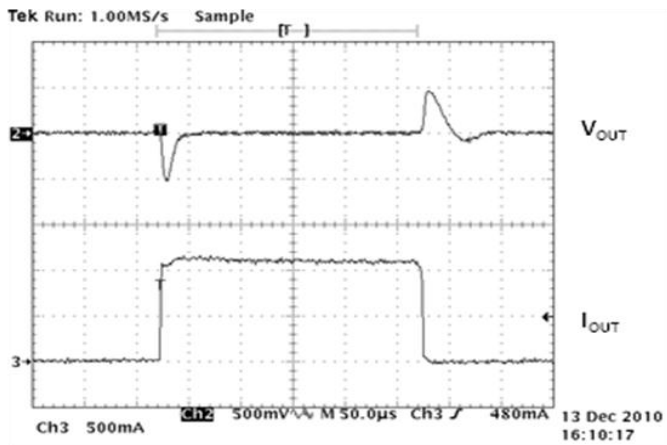

Application Hints

Input Capacitor (C_{IN})

An input capacitor may be required when the device is not near the source power supply or when supplied by a battery. This capacitor will reduce the circuit's sensitivity when powered from complex source impedance and significantly enhance the output transient response. The input bypass should be mounted with the shortest possible track directly across the regulator's input and ground terminals. A 10µF ceramic capacitor should be adequate for most applications.

Output Capacitor (C_{OUT})

The output capacitor provides not only stability to the regulator, but also, enhances the load transient response. A minimum capacitance of 10µF is required. When selecting a ceramic capacitor, only X5R and X7R dielectric types should be used. Other types such as Z5U and Y5F have such severe loss of capacitance due to effects of temperature variation and applied voltage, they may provide as little as 20% of rated capacitance in many typical applications.

Always consult the capacitor manufacturer's data curves before selecting a capacitor. High-quality ceramic capacitors can be obtained from Taiyo-Yuden, AVX, and Murata. Higher values of the output capacitance can be used to enhance loop stability and transient response.

The value of the output capacitor can be increased without limit. Higher capacitance values improve transient response, ripple rejection & reduce output noise.

Enable

The enable (EN) pin is active high and is compatible with standard digital signaling levels. When V_{EN} below 0.5V, it turns the regulator off while V_{EN} above 1.5V turns the regulator on. If not used, EN can be connected to the input Voltage. If EN is connected to V_{IN}, it should be connected as close as possible to the largest capacitance on the input to prevent voltage droops on that line from triggering the enable circuit.

Output Voltage

The adjustable output voltage option allows the user to select an output voltage by using an external resistor divider. ASD2306 uses a 1.27V reference voltage at the positive terminal of the error amplifier. To set the output voltage a programming resistor from the adjust pin (ADJ) to ground must be selected. A 10kΩ resistor is a good

selection for a programming resistor R2. A higher value may result in an excessively sensitive feedback node while a lower value will draw more current and degrade the light load efficiency. The equation for selecting the voltage specific resistor is:

$$V_O = \left(1 + \frac{R1}{R2}\right) * V_{FB}$$

For the fixed output devices, R1 and R2 are included within the device.

R2	R1	V _{OUT}
10kΩ	29kΩ	5.0V
10kΩ	16kΩ	3.3V
10kΩ	10kΩ	2.5V
10kΩ	4kΩ	1.8V
10kΩ	2kΩ	1.5V

Table 1: Feedback Resistor Values

Bypass

Connecting a capacitor between the BYP pin and ground can significantly reduce output noise. Values can range from 0pF to 10nF, depending on the sensitivity to output noise in the application. The start up speed of the ASD2306 is inversely proportional to the size of the bypass capacitor. Applications requiring a slow ramp-up of output voltage should consider larger values of bypass capacitance. Likewise, if rapid turn on is necessary, consider omitting C_{BYP}.

Thermal Consideration

The ASD2306 is designed to provide 300mA of continuous current in a very small package. Maximum power dissipation can be calculated based on the output current and the voltage drop across the part. To determine the maximum power dissipation of the package, use the junction-to-ambient thermal resistance of the device and the following basic equation:

$$P_{D(max)} = \left(\frac{T_{J(max)} - T_A}{\theta_{JA}} \right)$$

Where T_{J(max)} is the maximum junction temperature of the die, T_A is the ambient operating temperature, and θ_{JA} is layout dependent. The actual power dissipation

of the regulator circuit can be determined using the equation:

$$P_D = (V_{IN} - V_{OUT}) * I_{OUT} + V_{IN} * I_{SUP}$$

Substituting PD(max) for PD and solving for the operating conditions that are critical to the application will give the maximum operating conditions for the regulator circuit.

Device	Package	Output Voltage	Packing Method & Quantity
ASD2306M5	SOT23-5L	Adjustable	2500 Tape & Reel
ASD2306M5-1.2	SOT23-5L	1.2V	2500 Tape & Reel
ASD2306M5-1.8	SOT23-5L	1.8V	2500 Tape & Reel
ASD2306M5-3.3	SOT23-5L	3.3V	2500 Tape & Reel
ASD2306DF3308	DFN3X3-8	Adjustable	2500 Tape & Reel
ASD2306DF3308-1.2	DFN3X3-8	1.2V	2500 Tape & Reel
ASD2306 DF3308-1.8	DFN3X3-8	1.8V	2500 Tape & Reel
ASD2306 DF3308-3.3	DFN3X3-8	3.3V	2500 Tape & Reel

Ordering Information

Outline Drawing and Landing Pattern – SOT23-5

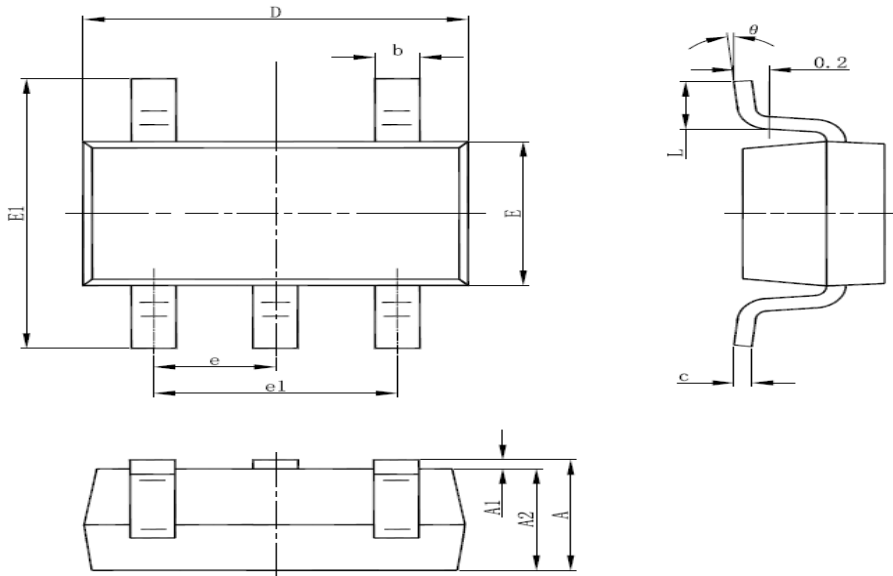

Symbol	Dimensions In Millimeters		Dimensions In Inches	
	Min	Max	Min	Max
A	1.050	1.250	0.041	0.049
A1	0.000	0.100	0.000	0.004
A2	1.050	1.150	0.041	0.045
b	0.300	0.500	0.012	0.020
c	0.100	0.200	0.004	0.008
D	2.820	3.020	0.111	0.119
E	1.500	1.700	0.059	0.067
E1	2.650	2.950	0.104	0.116
e	0.950(BSC)		0.037(BSC)	
e1	1.800	2.000	0.071	0.079
L	0.300	0.600	0.012	0.024
θ	0°	8°	0°	8°

Outline Drawing and Landing Pattern – DFN3X3-08

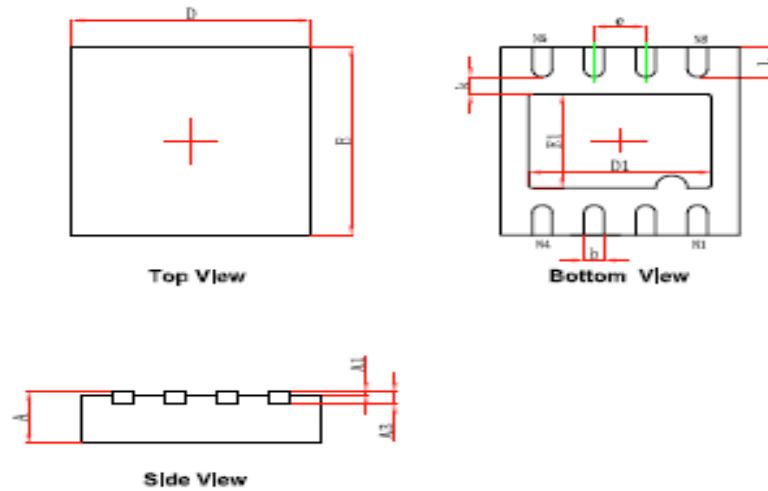

Symbol	Dimensions In Millimeters		Dimensions In Inches	
	Min.	Max.	Min.	Max.
A	0.700/0.800	0.800/0.900	0.028/0.031	0.031/0.035
A1	0.000	0.050	0.000	0.002
A3	0.203REF.		0.008REF.	
D	2.900	3.100	0.114	0.122
E	2.900	3.100	0.114	0.122
D1	2.200	2.400	0.087	0.094
E1	1.400	1.600	0.055	0.063
k	0.200MIN.		0.008MIN.	
b	0.180	0.300	0.007	0.012
e	0.650TYP.		0.026TYP.	
L	0.375	0.575	0.015	0.023

Disclaimer:

The information furnished in this data sheet is believed to be accurate and reliable. However, no responsibility is assumed by Golden Gate Integrated Circuits (GGIC) for its use. GGIC reserves the right to change circuitry and specifications at any time without notification to the customer.

- Golden Gate Integrated Circuits reserves the right to make changes to the information herein for the improvement of the design and performance without further notice! Customers should obtain the latest relevant information before placing orders and should verify that such information is complete and current.
- All semiconductor products malfunction or fail with some probability under special conditions. When using Golden Gate Integrated Circuits products in system design or complete machine manufacturing, it is the responsibility of the buyer to comply with the safety standards strictly and take essential measures to avoid situations in which a malfunction or failure of such Golden Gate Integrated Circuits products could cause loss of body injury or damage to property.
- Golden Gate Integrated Circuits (GGIC) Products are not designed or authorized for use as components in life support appliances, devices or systems where malfunction of a product can reasonably be expected to result in personal injury. Life support devices or systems are devices or systems that (a) are intended for surgical implant into the body or (b) support or sustain life, and whose failure to perform can be reasonably expected to result in a significant injury to the user. A Purchaser's use or sale of GGIC Products for use in life support appliances, devices or systems is a Purchaser's own risk and Purchaser agrees to fully indemnify GGIC for any damages resulting from such use or sale.